

# Screened Separable Connector

## For IEC Dead-break Type A Bushings



# RPAS

## Screened Straight Connector 250A up to 24 kV

Suitable for connecting all types of polymeric insulated cables to equipment with bushings Type A according to EN 50180 and EN 50181.

- For Voltage Range up to 12/20 (24) kV
- Impulse Voltage 125 kV
- Continuous current 250 A (300 A overload for 8 hours)
- Meets the requirements of IEC 60502-4 and CENELEC HD 629.1 S2
- No minimum phase clearance requirements
- Suitable for Copper or Aluminium Conductors from 25-120mm<sup>2</sup>
- Conductor connection by bimetallic compression type lug
- EPDM moulded body with semi-conductive outer layer
- Built-in capacitive test point to determine the circuit status
- Easy to install with comprehensive instructions included in each kit
- Each connector body is factory tested for partial discharge and AC withstand to ensure 100% reliability
- Unlimited shelf life at normal storage temperatures

### Standard Kit Contents:

- Set of 3 separable straight connector bodies
- Set of 3 bimetallic compression type lug and connecting pin
- Set of 3 stainless steel wire retaining bails
- Earthing connections and mastic sealants
- Installation materials and instructions



### Dimensions (mm):

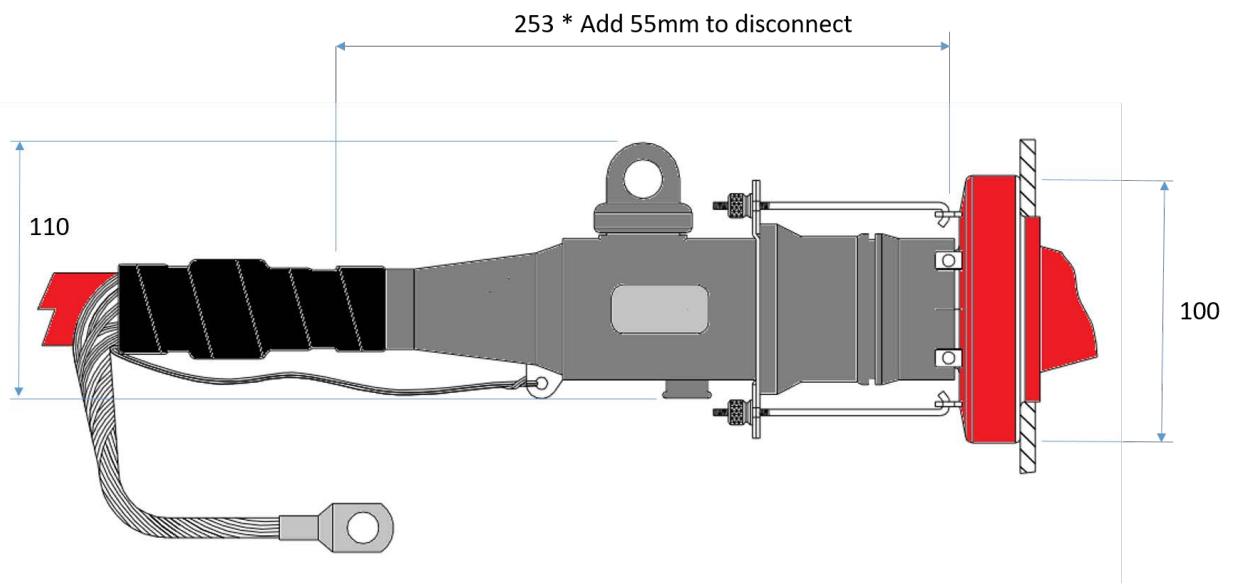

Please see overleaf for selection guide



# Screened Separable Connector

For IEC Dead-break Type A Bushings



## RPAS

### Screened Straight Connector 250A up to 24 kV

#### Selection Guide:

1. Select the elbow body type to fit over the prepared insulation according to the table :

Elbow Body Type "X"	Cable Insulation Diameter Ø Range (mm)
RPAS-J-D	17 - 22
RPAS-J-F	19.5 - 25
RPAS-J	27.9 - 33.5

2. Select the bimetallic cable lug to fit the conductor cross sectional area, according to the table:

Cable Lug Code "Y"	Cable Conductor Cross Section Area Range (mm <sup>2</sup> )
RMVL A250S 25-50	25-50
RMVL A350S 70-120	70-120

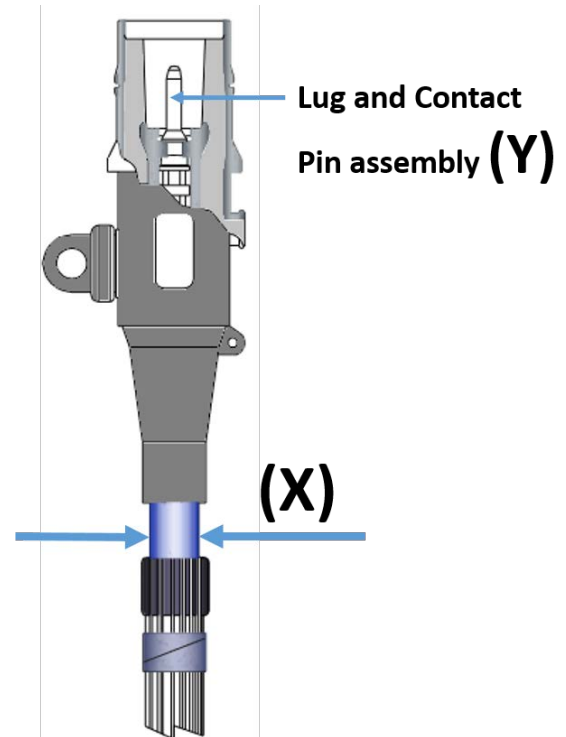

3. Full Product Code is determined by the adaptor selection and cable lug type :

#### How to select correct connector for cable size:

- 1/Select Body code according to the cable insulation diameter range in tables above
- 2/Select Adaptor Code (if needed) to the cable insulation diameter range in table above
- 3/Select the Mechanical Lug or Bimetallic compression lug to suit cable conductor cross section according to the tables above :

Full Product Code = Body Code/ Adaptor Code/ Lug Code e.g. [RPAS-J/D/25-50](#)

#### Notes

For cables with copper tape screens, an additional earth kit needs to be specified.

For 3-core cables, a trifurcating kit is available.

**Contact your local REPL Sales Office for details.**

REPL reserve the right to update the information contained in this document at any time without notice. It is the users responsibility to ensure it is suitable for the intended application. Any implied warranty relating to fitness for a particular purpose are explicitly excluded unless agreed in writing by REPL.

©REPL 2023

D  
A  
T  
A  
S  
H  
E  
E  
T

RPAS 23V1

