

RIHT(X)

REPL Heat Shrinkable Heavy Wall Heat Shrink Tubes (RIHTU/A) are used for environmental sealing of plastic and paper insulated cable joints. The tubes can be supplied with an internally coated adhesive layer or in an uncoated form depending on the application. These tubes are made from thermally stabilized, cross linked, UV and weather resistant polymeric material and have a nominal shrink ratio of 3:1. The tubes can be supplied internally coated with hot melt adhesive (RIHTA).

Features:

- Unlimited shelf life
- Excellent resistance to chemicals
- Excellent chemical properties
- Continuous operating temperature: 50°C to 125°C
- Conforms to specifications: IEC 60684=3, ENATS 09-11, RoHS 2011/65/EU & 2015/863/EU Compliant

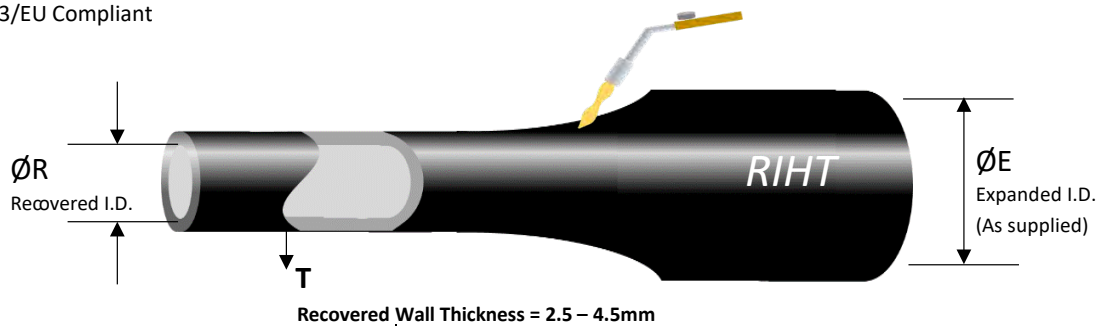

PRODUCT DIMENSIONS – RIHT (A) Series			
CODE	D (mm)		T (mm)
	E	S	S
	Min	Max	± 0.2
RIHTU (/A) 12/4	12	4	2.50
RIHTU (/A) 16/5	16	5	2.60
RIHTU (/A) 20/6	20	6	3.20
RIHTU (/A) 30/8	30	8	3.20
RIHTU (/A) 40/12	40	12	4.00
RIHTU (/A) 55/16	55	16	4.10
RIHTU (/A) 80/22	80	22	4.20
RIHTU (/A) 100/30	100	30	4.40
RIHTU (/A) 120/34	120	34	4.40
RIHTU (/A) 140/37	140	37	4.50
RIHTU (/A) 160/50	160	50	4.50
RIHTU (/A) 180/60	180	60	4.50

RIHTU – Uncoated Tube
 RIHTA – Coated Tube

*Custom sizes are available on request with minimum volume requirements

Colour = BLACK

MATERIAL SPECIFICATIONS		
CHARACTERISTIC	VALUE	TEST METHOD
Physical Properties		
Specific Gravity	1.19 ± 0.2 g/cm ³	ASTMD - 1505
Water Absorption	0.5% (max)	ASTM D – 570
Tensile Strength	≥14.5 N/mm ² (min)	ASTM D – 412 / ISO 37
Ultimate Elongation	500% (min)	ASTM D – 412 / ISO 37
Hardness	43 ± 3 Shore D	ASTM D - 2240
Longitudinal Change	±10%	ESI 09 - 13
Shrink Ratio	3 : 1 (Min)	TP / QA / 61
Torching	No Split	TP / QA / 7
Thermal Tests		
Shrink Temperature	120°C	IEC - 216
Heat shock (30 min 200° C)	No cracking / No flow	ESI 09-13
Heat Ageing (500 hrs 120° C)- Tensile Strength Ultimate Elongation	12 N/mm ² (min) 300% (min)	ASTM D-412 / ISO-37
Low Temp. Flexibility (- 40° C)	No cracking	ASTM D-2671
Electrical Properties		
Dielectric Strength	20 kV/mm (min)	ASTM D-149 / IEC-243
Volume Resistivity	1x10 ¹³ Ohm-cm (min)	ASTM D – 257 / IEC 93
Dielectric Constant	5 (max)	ASTM D-150 / IEC-250
Chemical Properties		
Fungus Resistance	No Growth	ASTM G - 21
Chemical resistance immersion in following liquids NaOH (40%), H ₂ SO ₄ (3%), Toluene acetone for 24 hrs at room temperature	Good (no change in appearance)	ISO 175

REPL reserve the right to update the information contained in this document at any time without notice. It is the users responsibility to ensure it is suitable for the intended application. Any implied warranty relating to fitness for a particular purpose are explicitly excluded unless agreed in writing by REPL.
 ©REPL 2023

DATA SHEET

RIHTX - 23V1